

TM1R Y R2

FORMADORA DE TELERAS MEJICANAS
MOULDER FOR MEXICAN TELERA BREAD

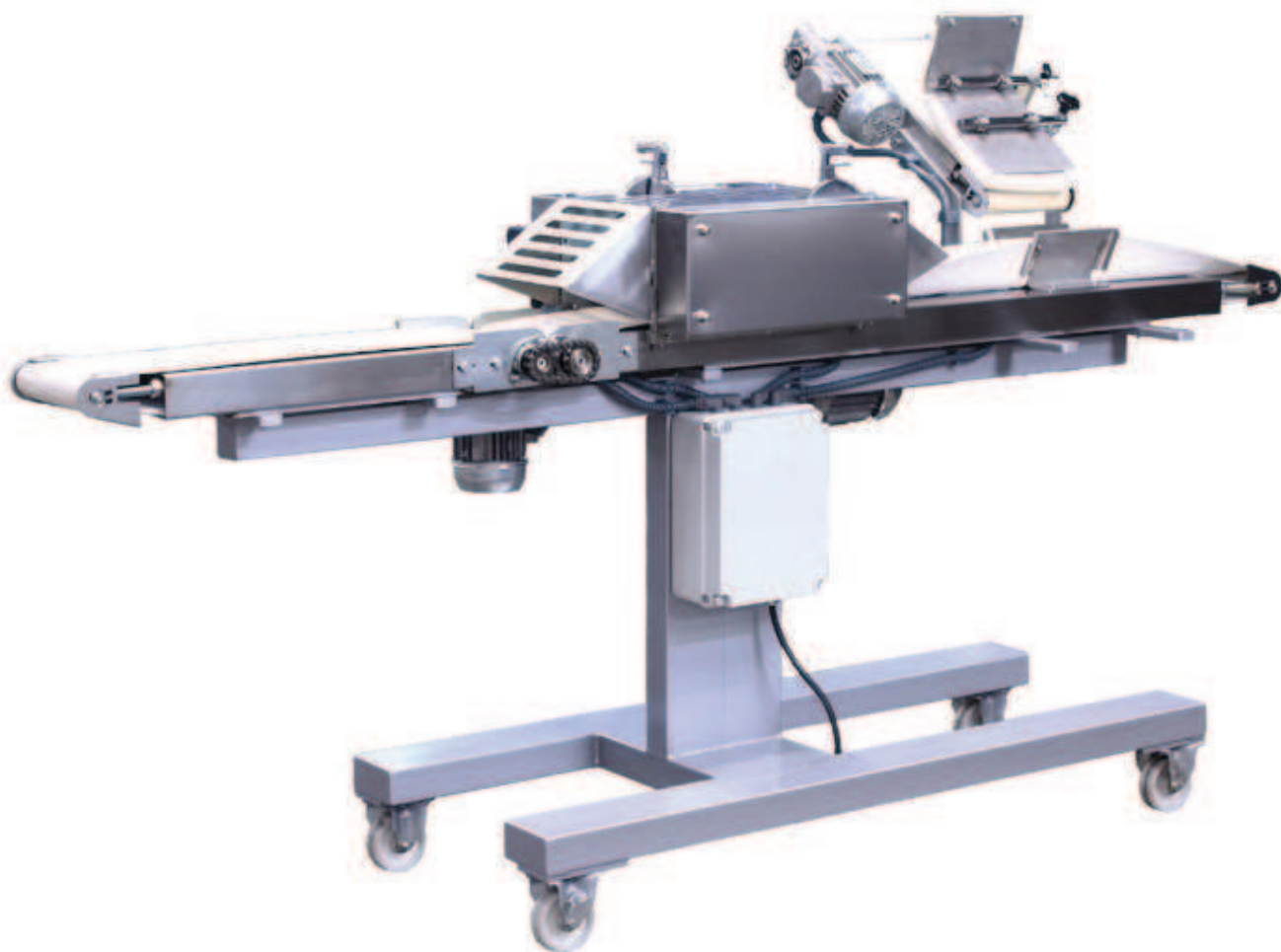

35
COLBAKE

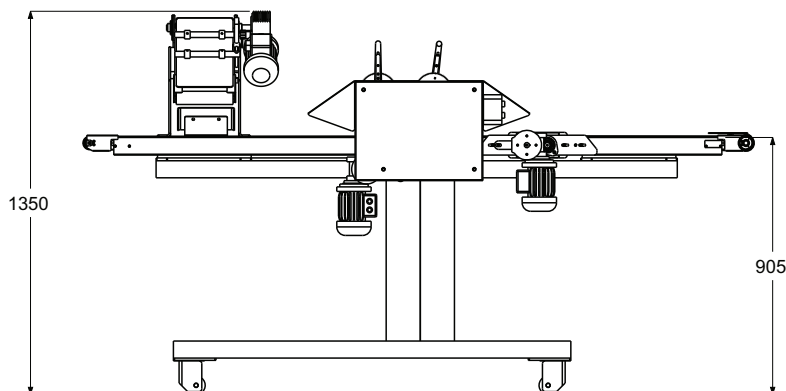

WWW.COLBAKE.COM





FORMADORA DE TELERAS MEXICANAS, PAPOSECOS PORTUGUESES O KEBAB

- Rodillo aplanador fabricado en material antiadherente.
- Discos marcadores fabricados en material antiadherente.
- Altura regulable del rodillo aplanador y discos marcadores.
- Prensa de preformado con cinta transportadora con sistema de centrado.
- Doble cinta transportadora para una fácil retirada de los productos ya formados.
- Manejo muy sencillo.
- Cubiertas de acero inoxidable.
- Potencia: 0,55 Kw.
- Voltaje: 3x380V ó 3x220V ó 1x220V (requiere variador electrónico de frecuencia).
- Dimensiones embalaje: 2,4x1x1,6m.
- Peso: 350kg.

MOULDER FOR MEXICAN TELERA BREAD, PORTUGESE PAPOSECOS OR KEBAB BREAD

- Flattening roller made of non-stick material.
- Marking discs manufactured in non-stick material.
- Adjustable height of the flattening roller and marking discs.
- Preforming press with conveyor belt with centering system.
- Double conveyor belt for easy removal of already formed products.
- Very simple use and maintenance.
- Stainless steel covers.
- Power: 0,55 Kw.
- Voltage: 3x380V or 3x220V or 1x220V (requires electronic frequency converter).
- Packing dimensions: 2,4x1x1,6m.
- Weight: 350kg.

